





## Ghoti

### Ghoti papers

Ghoti aims to serve as a forum for stimulating and pertinent ideas. Ghoti publishes succinct commentary and opinion that addresses important areas in fish and fisheries science. Ghoti contributions will be innovative and have a perspective that may lead to fresh and productive insight of concepts, issues and research agendas. All Ghoti contributions will be selected by the editors and peer reviewed.



### Etymology of Ghoti

George Bernard Shaw (1856–1950), polymath, playwright, Nobel prize winner, and the most prolific letter writer in history, was an advocate of English spelling reform. He was reportedly fond of pointing out its absurdities by proving that 'fish' could be spelt 'ghoti'. That is: 'gh' as in 'rough', 'o' as in 'women' and 'ti' as in palatial.

## By-catch begone: changes in the philosophy of fishing technology

Steven J Kennelly<sup>1</sup> and Matt K Broadhurst<sup>2</sup>

<sup>1</sup>NSW Fisheries, Cronulla Fisheries Centre, PO Box 21 Cronulla, NSW 2230, Australia; <sup>2</sup>NSW Fisheries, Conservation Technology Unit, National Marine Science Centre, PO Box J321, Coffs Harbour, Australia

### Abstract

Since humans began fishing (at least 90 000 years ago), fishing technology has developed with the objective of trying to catch the greatest quantities of fish possible, of an ever-increasing variety. Fishing technology has evolved from simple harpoons and hooks to the industrial factory trawlers of the 20th century. After millennia of assuming that seafood resources are inexhaustible, and centuries of somewhat muted concerns that advanced fishing technologies may have detrimental impacts on stocks and ecosystems, the last century has seen advances in fishing technology blamed as a major cause of the current over-exploitation of fish stocks. It has mainly been during the last few decades that fishing technologists have begun to focus on more conservation-orientated goals. This occurred initially in response to concerns over the by-catch of charismatic species (like dolphins in tuna purse-seines), but quickly broadened to address concerns over the discarding of not-so-charismatic species (like juvenile fish killed by shrimp trawling). To ameliorate these issues, technologists and commercial fishers successfully developed various innovative gear-based and operational solutions. The steps involved in successfully reducing by-catches have tended to follow a certain incremental framework involving identification of problems using observer programmes, developing technological solution to these problems, experimentally testing these solutions, implementing these solutions throughout industry and finally gaining acceptance of the solutions from concerned interest groups. Most recently public concern has broadened once again from by-catch issues to encompass a much wider context involving the impacts of fishing on entire ecosystems, i.e. the impacts of fishing on all species affected – not just those species caught, retained or discarded. As a

### Correspondence:

Steven J. Kennelly,  
NSW Fisheries,  
Cronulla Fisheries  
Centre, PO Box 21,  
Cronulla, NSW 2230,  
Australia  
Tel.: +61 2 9527 8532  
Fax: +61 2 9527 8513  
E-mail: kennells@  
fisheries.nsw.gov.au

Received 28 Aug 2001

Accepted 21 June 2002

consequence, there have been many calls for ecosystem-based fisheries management to ensure that fisheries operate under the principles of ecologically sustainable development. Scientists are gradually filling the gaps in our knowledge about how fishing affects whole ecosystems but, because of the scales and complexities involved, such studies are usually difficult, expensive and of long duration. While this descriptive work is difficult, finding solutions to any identified problem is an even greater challenge, particularly for fishing technologists. The easiest solutions to such problems involve rather draconian management strategies like closures. A less extreme alternative involves the development of new technologies that reduce the impacts of fishing on ecosystems – in a similar way as that done to reduce by-catch problems. Innovations like altering ground-chains, footropes, sweeps and trawl doors have been suggested as possible ways to ameliorate the environmental damage done by trawling, but such research is still very much in its infancy. Nevertheless, the recent history of fishing technology is cheered with successfully meeting such challenges, giving one confidence that solutions to such issues may eventually be developed. Integral to the success of any solutions that strive towards the goal of perfect selectivity, however, is a corresponding improvement in the adoption of these methods by fishers. As our framework shows, this is best achieved by involving fishers in all aspects of the work.

**Keywords** by-catch reduction, discards, ecosystems, fishing technology, over-exploitation

---

### **Beginnings – fishing technology developed to exploit an ‘inexhaustible’ supply**

In 1995, Yellen *et al.* described the discovery of barbed and unbarbed bone fragments in the upper Semliki Valley in Zaire (Fig. 1). These fragments, dated from approximately 90 000 years ago, were found in association with the remains of large catfish, indicating the use of harpoons to catch fish. This marks the first known use of fishing technology by humans, who no doubt regarded it as a significant ally in their struggle to survive. From these beginnings, the primary goal of fishing technology throughout prehistory was to develop better techniques to increase the quantity and diversity of fish landed – a goal that has remained the priority of fishers for millennia – with little attention given to the impacts of such techniques on the stocks exploited or their ecosystems (see Pitcher 2001 for a review).

By 2000 years ago, fishing technology had developed a large diversity of methods. The Bible provides some of the earliest written descriptions of some of the basic techniques used at the time: angling with rods and hooks on flaxen line; flaxen cast nets; fish traps and pronged tridents (see Wuellner 1967; Nun 1989, 1993). The most common mode of fishing in the

Sea of Galilee in biblical times involved cast nets and larger dragnets and, whilst these techniques were designed to catch the maximum quantity and diversity of fish possible, it is also apparent that the discarding of unwanted, dead fish was commonplace. One of the first recorded mentions of the impacts of fishing on nontargeted species is attributed to Jesus Christ in his ‘Parable of the Fishing Net’: “Also, the kingdom of heaven is like a net thrown out in the lake, which catches all kinds of fish. When it is full, the fishermen pull it to shore and sit down to divide the fish: the good ones go into their buckets, the worthless ones are thrown away” (Matthew, 13.47).

Despite discarding practices being a feature of fishing 2000 years ago, there was still no recognition of any negative aspects of such discarding on stocks or ecosystems. Such a philosophy typifies the thoughts of not only fishers from ancient times, but also most fishers until recently. That is, for most of recorded history (and prehistory), humans have tended to consider fishing technology as a major aid in providing a seemingly inexhaustible supply of seafood. With the benefit of archaeological evidence, we now know that technological advances have led to major reductions in biodiversity and the progressive depletions of many fish populations (Pitcher 2001).



**Figure 1** Bone fragments from the Upper Semliki Valley, Zaire, 90 000 years ago (from Yellen *et al.* (1995)).

### The 14th to 19th centuries – beginning to see a problem

It was not until the 14th century that we begin to see any mention that fishing technology could be leading to negative impacts on stocks and ecosystems (see Dyson 1977 for a summary). In the River Thames, for example, the capture of immature fish was illegal as early as 1320; in 1349 it was recorded that 15 nets were confiscated that contained three bushels of fish 'which, by reason of their smallness, could be of no use to anyone'.

Fishers of this era were particularly concerned about a 'new and subtly contrived instrument' known as the 'wondyrchoun' (meaning 'wondrous ability') (Dyson 1977). This early beam trawl had been in use for about 7 years when Edward III was petitioned in 1376 about the declines of fish it may have been causing:

The great and long iron of the wondyrchoun runs so heavily and hardly over the ground when fishing that it destroys the flowers of the land below the water, and also the spat of oysters, mussels and other fish upon which the great fish are accustomed to be fed and nourished. By which instrument in many places the

fishermen take such quantity of small fish that they know not what to do with them; and they feed and fat their pigs with them, to the great damage of the Commons of the Realm and the destruction of the fisheries' (as cited in Dyson 1977).

A royal commission reported that the wondyrchoun was 3 fathoms long and 10 feet wide, had a beam 10 feet long and a leaded rope weighted with big stones fixed on the lower part of the net – which comprised meshes the length and breadth of two thumbs. The commission advised that the net ought to be used only in deep water and not in estuaries, but no legislation was enacted. The 14th century outcry against this technology began a battle that was repeated in the 1620s when Charles I considered the impacts on stocks by the net that was, by then, called the 'trawle'. It is a conflict that has, of course, continued to the present day.

The 19th century saw a dramatic increase in the use of most of the major methods of fishing applied today. Previously, longlines and drift nets were the main gears used, although beam trawls, beach seines and trap nets had also been used to a lesser extent for centuries (see above). The first recorded use of the purse-seine was in the USA in 1826, the Danish seine

was invented by Jens Laursen Vaever in Denmark in 1848 and the modern-day otter trawl was first used in England or Ireland around 1860. The arguments against trawling and other contemporary methods of fishing continued throughout that century with several parliamentary commissions appointed to consider the issue. However, the efficiency of these methods (and in particular, the trawl) in catching large quantities of fish always prevailed, establishing them as the prime tools used to catch fish up to the present day.

### **Into the 20th century – unchecked technology, overfishing and impacts on ecosystems**

The warnings from the 14th to 19th centuries about the negative impacts that advances in fishing technology might be having on stocks and ecosystems were realized in the 20th century, particularly during the second half, when major declines occurred in the world's fishing stocks. The unchecked construction of bigger vessels (culminating in huge factory trawlers) combined with advances in electronic equipment and netting materials and designs, all led to a strong test of the millennia-old assumption that

seafood resources were inexhaustible. This is an assumption that we now know is false.

A particularly well-documented example of the consequences of allowing fishing technology to develop unchecked is found in the groundfish fisheries off the north-eastern USA (see NOAA 2001 for a summary). Fishing for cod, haddock, redfish and flounders initially involved baited lines fished from schooners and their dories (Fig. 2), but these were replaced by steam-powered trawlers in around 1906. At this time, there were considerable warnings that the new technology could threaten the productivity of stocks, but these had no effect on fishing practices. Demand quickly grew as improvements in storage, marketing and distribution occurred and this led to even greater landings. By 1930, there were clear signs that fishing effort had grown too large for sustainable yields and the fishing methods used were quite non-selective (e.g. in 1930 the fishery was estimated to have landed 37 million haddock at Boston and owing to the small mesh size used, another 70–90 million small haddock were estimated to have been discarded dead at sea). Landings began to fall and scientists recommended increasing mesh size, but no formal agreements occurred. The beginning of the 1960s saw the controversial arrival of large high-seas



**Figure 2** Schooners and dories line-fishing on the Grand Banks (by H.W. Elliot and Capt. J.W. Collins).



**Figure 3** The launch of the Atlantic Dawn, in February, 2000 (from Fishing News International, March 2000).

factory trawlers from the USSR, East Germany, Poland, Spain, Japan and other countries. In the early 1970s, continued declines in stocks eventually led to the US Magnuson Act in 1976, which took control of the exclusive economic zone and established a system to regulate the domestic industry. This led to great expectations in the industry and, aided by subsidy programmes, many new, modern trawlers were built. Fishing effort therefore continued to increase and many of the most productive stocks in the region declined. In the late 1980s, various environmental groups sued the US government for not adequately enforcing laws mandating against the overfishing of resources. This led to new management plans to control fishing effort and rebuild stocks.

The above example is just one of the many accounts of increasing demand and unchecked technology leading to stock collapses in many parts of the world throughout the 20th century. The trend for bigger, more powerful vessels continues today, with the largest fishing vessel in the world launched in February 2000 (Fig. 3). This 14 000-t ship (the 'Atlantic Dawn') was built in Norway for an Irish company, is 145 m long, cost £50 m, has a crew of 100 and can hold enough fish to feed 14 million people for a day. Given recent history, one must wonder how long such vessels can remain profitable.

### The last few decades – a change in philosophy

So, after tens of thousands of years developing better techniques to catch fish, centuries of concern that such techniques may be causing significant damage to stocks and ecosystems, and half a century of realising that such impacts were occurring, the last two decades have seen a major change in focus in the field of fishing technology. This has occurred as scientists

and fishers tried to develop techniques that permit the exploitation of fish stocks in a more sustainable manner. The first major impetus for this change was the issue over 'by-catch' (the capture and discard of untargeted individuals and species). Concern over this issue surfaced periodically throughout history (see above), but recently reached a maximum due to declining fish stocks and widespread publicity over the incidental capture of charismatic species like dolphins and turtles. These factors led to commercial and recreational fishers, conservationists, environmentalists, politicians, fisheries managers and scientists, all identifying by-catch as a key problem and calling for ways to reduce it (for reviews see Alverson *et al.* 1994; Kennelly 1995). In response to this challenge, fishing technologists have been successful in developing technologies to protect many organisms while still allowing target species to be caught. Two examples are described below.

Interestingly, despite centuries of concern over the discarding of small fish from nets (especially trawls), one of the first attempts to resolve by-catch issues did not address trawling but the more selective method of purse-seining (for a full description of this example, see Hall 1994, 1998). Concern over the incidental mortality of dolphins in tuna purse-seines has been one of the world's most infamous by-catch issues since the 1960s with dramatic outcries from various environmental and conservation organizations. The most common way purse-seiners fish in the eastern Pacific Ocean is to encircle groups of dolphins to catch the tuna that they swim with. During the 1960s, the incidental mortality of dolphins using this method was an average of approximately 350 000 dolphins year<sup>-1</sup>, which is believed to have caused significant declines in their populations. But through the development of a series of technological and other modifications, dolphin mortalities were reduced in this fishery to negligible levels (Hall 1994,

1998). These modifications included different mesh sizes in certain sections of the nets, modified methods for tying the cork line, a manoeuvre termed 'back-down' after dolphins were encircled (see Fig. 4 and Medina 1994), using speedboats to 'herd' dolphins to the rear of the net, and avoiding areas containing populations of particularly prone dolphins. Once these modifications were developed, a large-scale education programme trained skippers and crews in the new techniques. The success of the work done in

this fishery showed that it was possible to save bycaught dolphins without closing a major fishery.

Another, virtually global, example of how fishing technology became an ally in minimising impacts of fishing is the success that various types of by-catch reduction devices (BRDs) have had in decreasing the unwanted by-catch of large numbers of juvenile fish from shrimp trawls (for a recent review, see Broadhurst 2000). Much of this work began in the Gulf of Mexico and Europe more than 20 years ago, but the



**Figure 4** The 'backdown' manoeuvre used in tuna purse-seining.

example that we will use to illustrate it comes from work done in New South Wales (NSW), Australia.

In NSW, high-profile by-catch problems in shrimp fisheries have occurred since the late 19th century (see Dannevig 1904; for review see Kennelly 1995) but reached a maximum in the late 1980s with threats to close certain fisheries to stop the by-catch of juvenile fish. An observer programme estimated large by-catches of juvenile fish in these fisheries (Kennelly *et al.* 1993, 1998; Liggins and Kennelly 1996). For example, in the Clarence River in 1991–92, it was estimated that in catching 270 tons of shrimp, 123 tons of by-catch was discarded, including 0.8 million individuals of the recreationally and commercially important yellowfin bream. In the oceanic

fishery offshore from this river in the same year, it was estimated that in catching 288 tons of shrimp, 4 022 tons of by-catch was caught, of which 725 tons was landed for sale as 'byproduct' (including various species of slipper lobsters, squid, octopus and large fish) while the rest (some 3 297 tons) was discarded.

After a series of experiments (see Broadhurst 2000 for details), two gear modifications proved successful at reducing by-catch while maintaining and sometimes even enhancing catches of shrimp. Because the targeted shrimp in the estuarine fishery were smaller than the by-catch to be excluded, a modified Nordmøre-grid (Isaksen *et al.* 1992) was found to be most effective (Fig. 5). For the oceanic fishery, a composite square-mesh panel anterior to the codend (see

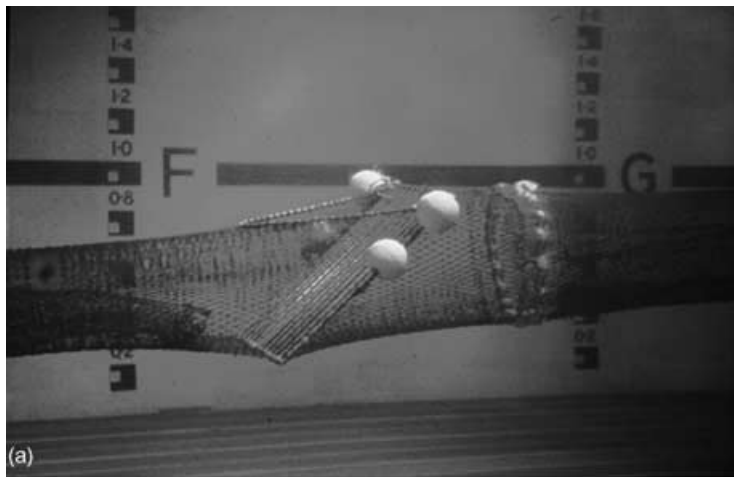

**Figure 5** The Nordmøre-grid used in the NSW estuarine shrimp trawl fishery and an example of the catches from paired comparisons using a conventional codend (a) and one with a Nordmøre-grid (b).

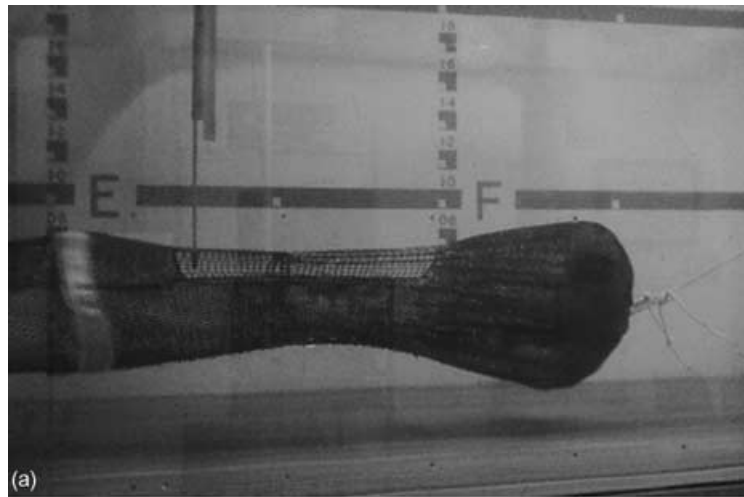

**Figure 6** The composite square-mesh panel tested in the NSW oceanic shrimp-trawl fishery and an example of the catches from paired comparisons using a conventional codend (a) and one with a composite square-mesh panel (b).

Fig. 6) was developed that allowed small fish to swim out of the codend, while commercially important shrimp, slipper lobsters, squid and octopus were retained. The sizes of fish excluded could be selected by adjusting the mesh size in the square-mesh panel. Both these modifications are now among the BRDs that are mandatory in NSW's shrimp fisheries.

#### **A framework for solving by-catch problems**

The case studies above illustrate that technological solutions can be employed to address successfully the issue of by-catch in different fisheries. Further, it has been shown that this has generally occurred only when an incremental protocol or framework is employed (Fig. 7) (Kennelly and Broadhurst 1996; Kennelly 1997; Broadhurst 2000). This framework

involves five key steps: (i) quantifying by-catches; (ii) identifying the main by-catch species of concern; (iii) developing modifications that minimize mortality of these species; (iv) testing the alternatives in field experiments; and (v) gaining acceptance of the new technology throughout the particular fishery and finally to interested groups.

The logic and methods for completing steps (i), (ii), (iv) and (v) are common among many fisheries and have been described in detail by Kennelly and Broadhurst (1996), Kennelly (1997), (1999) and Broadhurst (2000). The development of new fishing technologies that minimize by-catches (step iii) is a more complicated step and largely depends on the characteristics of the fishery in question. For example, in the case of active fishing gears, like trawls and seines, this has nearly always involved different types of physical

## The problem: concern over the by-catch from fishing

1. Identify and quantify the problem via observer programs
  - scientists working with fishers on typical fishing trips
2. Identify by-catch species of main concern, their sizes, location and time
  - scientists and fishers examining data on by-catches and determining required rates of reduction
3. Develop modifications to improve selectivity
  - scientists' ideas from other studies and the literature
  - fishers' ideas, experiences and unique knowledge of the gear
4. Test modifications to improve selectivity
  - scientists doing field experiments onboard fishers' vessels
  - scientists analysing the data for the best solution
  - fishers making solutions practical for their operations
5. Implement appropriate modifications to improve selectivity
  - scientists doing talks, videos, articles, papers to publicize solution to fishers not directly involved in the tests
  - fishers discussing and teaching each other how to use the new gear
  - scientists and fishers publicizing the results to other interested groups

and so reduce concerns, solving the problem



**Figure 7** The framework for solving by-catch problems.

modifications to improve selectivity (Fig. 8). Depending on the species to be excluded and retained, these modifications range from simple changes to existing mesh sizes and materials (e.g. Broadhurst *et al.* 2000; Gray *et al.* 2000; Kennelly and Gray 2000) to the application of specific and often complicated BRDs (Fig. 8; Broadhurst 2000). These BRDs separate catches either mechanically according to their sizes (e.g. rigid devices like the Nordmøre-grid) or via differences in physiology and/or behaviour (e.g. like the composite square-mesh panel). In some cases, by combining devices that incorporate the principles of both mechanical separation (as primary BRDs) and behavioural separation (as secondary BRDs), it is possible to allow a large range of different species and sizes to escape nets (Fig. 8; Broadhurst 2000).

BRDs are generally limited to active fishing gears; however, the underlying factors governing their effectiveness (i.e. differences in the behaviour and physiology of target and nontarget species) are also

being used to improve selectivity of passive fishing gears. As an example, the size, morphology, condition and behaviour of fish have been shown to be important factors influencing the selectivity of traps (e.g. Stewart and Ferrell 2002) and gillnets (e.g. Hay *et al.* 1986; Hovgård 1996; Poulsen *et al.* 2000). Similarly, species-specific variabilities in feeding behaviour and preferences for different sizes and types of baits have been shown to influence the composition, size and quantity of fish caught by longlines (Løkkeborg and Bjordal 1992; Broadhurst and Hazin 2001). Other successful solutions to reduce by-catch have simply involved subtle changes to the operation of traditional fishing gears, such as different setting methods of longliners to reduce by-catches of sea birds (Løkkeborg 1998) or the backdown procedure used to reduce by-catches of dolphins from tuna purse-seines (see above).

The various studies described above serve to illustrate that many by-catch problems can be resolved

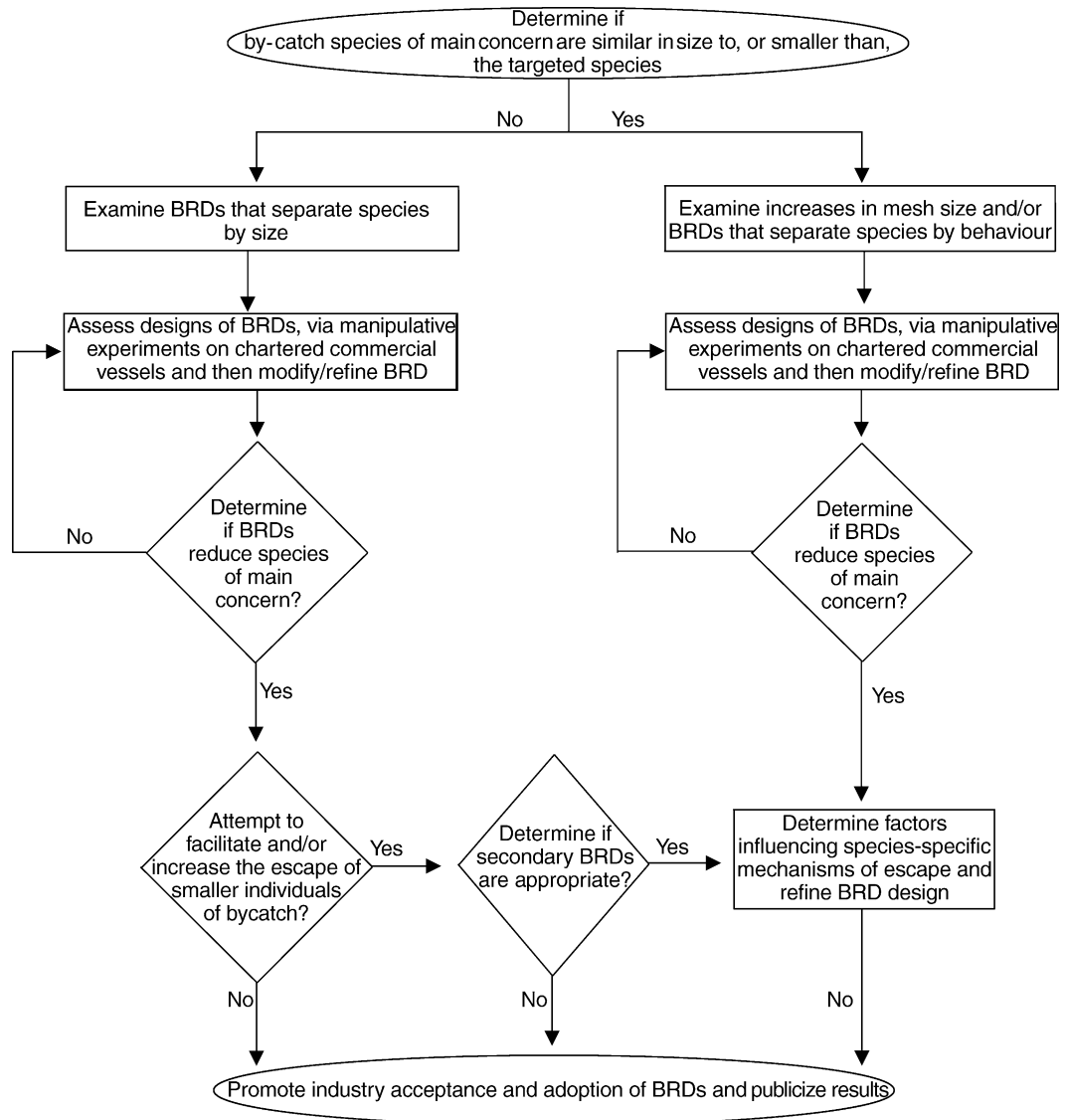

**Figure 8** Summary of the logic used for developing and testing modifications in shrimp-trawl fisheries.

via technological solutions, but that this must be done on a fishery-specific basis. Further, it is apparent that the successful adoption and use of these technological solutions will only occur when fishing industries are involved in all stages of the framework (Kennelly 1997, 1999).

### Current issues

The brief history of fishing technology summarized above shows how the focus of the field has changed. For most of the time since humans began catching fish, fishing methods were developed to maximize catches of an ever-increasing diversity, with little

regard for any of the likely environmental impacts. But in recent times, attention has shifted towards some of the more obvious environmental issues connected with fishing, beginning with concerns over the by-catch, discard and wastage of charismatic species and expanding to concerns over not-so-charismatic species like the small fish killed during shrimp and fish trawling. In response to these issues, fishing technologists and commercial fishers developed various gear-based and operational solutions (like those discussed in the previous section) that ameliorated many of the problems.

During the past decade, public concern has broadened once again to encompass a much wider con-

**Table 1** Summary of a brief review of the literature examining ecological impacts of fishing

(a) Papers assessing impacts		
Sainsbury (1991)	Sainsbury <i>et al.</i> (1997)	Simboura <i>et al.</i> (1998)
Eleftheriou and Robertson (1992)	Auster (1998)	Thrush <i>et al.</i> (1998)
Brylinsky <i>et al.</i> (1994)	Brailovskaya (1998)	Tuck <i>et al.</i> (1998)
Kaiser and Spencer (1994)	Collie (1998)	Auster and Langton (1999)
Witbaard and Klein (1994)	Dorsey and Pederson (1998)	DeAlteris <i>et al.</i> (1999)
Dayton <i>et al.</i> (1995)	Gilkinson <i>et al.</i> (1998)	Freese <i>et al.</i> (1999)
Thrush <i>et al.</i> (1995)	Gordon <i>et al.</i> (1998)	Friedlander <i>et al.</i> (1999)
Auster <i>et al.</i> (1996)	Jennings and Kaiser (1998)	Hall-Spencer <i>et al.</i> (1999)
Currie and Parry (1996)	Kaiser (1998)	Hill <i>et al.</i> (1999)
Kaiser (1996)	Kaiser <i>et al.</i> (1998)	Jennings <i>et al.</i> (1999)
Kaiser and Spencer (1996)	Lindeboom and de Groot (1998)	Kaiser <i>et al.</i> (1999)
Kaiser <i>et al.</i> (1996)	Pilskaln <i>et al.</i> (1998)	Lindeman and Snyder (1999)
Morton (1996)	Poiner <i>et al.</i> (1998)	Prena <i>et al.</i> (1999)
Ramsay <i>et al.</i> (1996)	Pranovi <i>et al.</i> (1998)	Tegner and Dayton (1999)
Collie <i>et al.</i> (1997)	Ramsay <i>et al.</i> (1998)	Hansson <i>et al.</i> (2000)
Jennings and Polunin (1997)	Rogers <i>et al.</i> (1998)	Lindegarh <i>et al.</i> (2000a)
Kaiser and Ramsay (1997)	Schwinghamer <i>et al.</i> (1998)	Lindegarh <i>et al.</i> (2000b)
(b) Papers suggesting technological solutions		
Seidel (1969)		
Watson (1976)		
Carr and Milliken (1998)		

text involving the impacts of certain fishing methods on whole ecosystems (Pitcher 2001). One of the most pressing issues facing the world's fisheries today concerns the impacts of fishing on all species affected – not just those that are caught, retained or discarded, but also the ecological implications of disrupting habitats and the many uncaught species affected (see Kaiser *et al.* 1998; Watling and Norse 1998; Freese *et al.* 1999; Lindegarh *et al.* 2000a,b). While the species that comprise the biodiversity of these systems (sponges, ascidians, byozoans, polychaetes, microscopic organisms, juveniles of commercially exploited species, etc.) have little charisma, public appeal or commercial priority, their role is seen as critical because they underpin much of the local ecology. Add this to the fact that most fisheries rely on the continued normal functioning of these ecosystems and it becomes obvious that the fishing industry itself is, or at least should be, concerned about these issues.

As a consequence of this latest stage in humans' perceptions of fishing, there have been several initiatives calling for ecosystem-based approaches to fisheries management. Further, issues concerning biodiversity and ecosystem-wide effects of fishing are now central to most management plans where there are policies to manage in an ecologically sustainable manner. A corollary is that there are now significant demands for more scientific information

on the ecological impacts of fishing and finding solutions that will minimize it.

In recent years, there has been a substantial effort by scientists to increase our knowledge of these issues, but because of the scales and complexities involved, such studies are usually difficult, expensive and of a long duration. In a reasonably thorough (but by no means exhaustive) examination of this literature (Table 1), a significant number of studies (51) have attempted to measure the ecological impacts of fishing (especially using active gears like trawls), but very few (3) have addressed such impacts via technological solutions. The solutions suggested so far in this debate usually involve stopping fishing in sensitive areas and times – not to develop technological solutions to ameliorate problematic impacts. It is interesting that this initial consideration of closure strategies – instead of technological solutions – repeats the pattern that characterized early strategies on ways to deal with by-catch issues before advances in fishing technologies were developed.

### The next challenge

The above discussion places us in the midst of the next major challenge for fishing technologists: to address the ecological impacts of fishing so that fishing can continue in an ecologically sustainable fashion. It is this challenge that should now be adopted

by fishing technologists. Attempts to address this issue will logically begin with the infamous fishing technique of trawling and, as those European and American fishing technologists found decades ago as they began developing BRDs for shrimp trawls, we have very little research available on this issue with which to build.

One concept that comes to us from work done many years ago examines an alternative to the use of ground chains on demersal trawls. Seidel (1969) and Watson (1976) describe the utility of electric fields as a replacement for ground chains in making shrimp 'jump' into the path of an oncoming net but, despite its potential, no further development of this concept occurred. Carr and Milliken (1998) summarized several options for minimising impacts of trawl gear on the sea floor. One was to rig trawls so that foot-ropes were raised when targeting fish that school slightly above the bottom. Others involved modifying the configuration of sweeps using various types of rollers, 'rock hoppers' and 'street sweepers' to minimize impacts of trawls on benthic assemblages. Several quite simple but effective solutions have been discussed at recent meetings and workshops on this subject, including: (i) decreasing the warp length-to-depth ratio as much as possible to decrease the weight of trawl gear on the bottom; (ii) reducing the lengths of sweeps and bridles as much as possible; (iii) maintaining net spread to reduce the likelihood that the net belly contacts the bottom; and (iv) using floats on BRDs and codends to avoid them hitting the bottom (Whyte, personal communication).

Some of the more promising ideas to surface in recent years concerns the operation of otter boards (Whyte, personal communication) which are dragged along the substratum and have the potential

to disturb it more than any other component of trawl gear. One way to reduce this disturbance may be to use rollers or wheels set into universal joints on the base of the boards or to have their basal shoes offset at an angle from the main part of the board (Fig. 9). This would allow the shoe to slide over the substratum in the direction of the tow and so reduce the contact of the board to the width of the shoe; up to 90% less than the length of the board.

While it is encouraging that there are several technological options available for reducing impacts of trawl gears on habitats, it is disappointing that so few have actually been tested. This is the challenge now facing fishing technologists and commercial fishers throughout the world as they try to continue fisheries on a sound, ecologically sustainable footing. We believe that such a challenge can be met optimistically by this field because its recent history in dealing with by-catch issues illustrates a successful shift in philosophy and paradigms to meet environmental challenges – after many millennia of ignoring them.

### The future

There is no doubt that the worldwide demand for seafood will continue to rise and, whilst increased production from aquaculture may meet some of this demand, there will always be increasing pressure to harvest wild stocks. For this to occur in a sustainable fashion, the techniques used to harvest fish will have to become increasingly selective. We believe that fishing technology will evolve considerably closer to the point where only those species and sizes/ages of species are caught whose removal can be withstood and sustained – not only by the exploited populations, but by the ecosystems which support them.

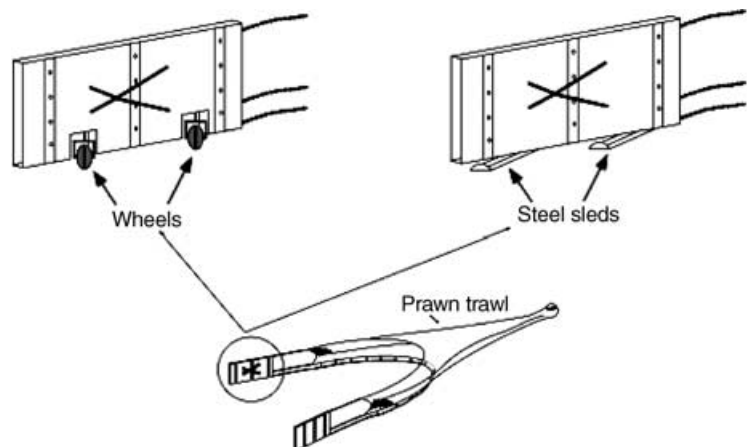

**Figure 9** Two options that may reduce the ecological impacts of otter boards – using wheels and angled sleds on the base of boards.

We see this rather optimistic view as not a hopeful desire but as an inevitable consequence of the state of the world's exploited fish populations and the ever-increasing pressure on them. Quite simply, if fishing technology does not develop to an almost 'utopian' point of perfect selectivity, the fisheries of the world will continue to decline at its current (or a faster) rate.

However, as fishing technologists work towards this ultimate goal, there also needs to be a corresponding increase in the willingness of the commercial and recreational fishing sectors to adopt such technologies. Whilst legislation by governments can provide some impetus for fishers to adopt selective fishing practices, recent history has shown that the most effective uptake requires the involvement of fishers at all stages of development. As our framework (Fig. 7) shows, this should occur from the original identification and quantification of particular by-catch and selectivity issues, through the design and testing of new gears, to the education, adoption and advertising of resultant solutions. Unless this engagement and involvement of fishers is as fully developed as the fishing technology itself, perfect selectivity of fishing practices will never occur – no matter how perfectly selective fishing technologists make them.

## References

- Alverson, D.L., Freeberg, M.H., Murawski, S.A. and Pope, J.G. (1994) A global assessment of fisheries by-catch and discards. *FAO Fisheries Technical Paper* 339. FAO, Rome, 233pp.
- Auster, P.J. (1998) A conceptual model of the impacts of fishing gear on the integrity of fish habitats. *Conservation Biology* **12**, 1198–1203.
- Auster, P.J. and Langton, R.W. (1999) The effects of fishing on fish habitat. *American Fisheries Society Symposium* **22**, 150–187.
- Auster, P.J., Malatesta, R.J., Langton, R.W. et al. (1996) The impacts of mobile fishing gear on seafloor habitats in the Gulf of Maine (Northwest Atlantic): implications for conservation of fish populations. *Reviews in Fisheries Science* **4**, 185–202.
- Brailovskaya, T. (1998) Obstacles to protecting marine biodiversity through marine wilderness preservation: examples from the New England region. *Conservation Biology* **12**, 1236–1240.
- Broadhurst, M.K. (2000) Modifications to reduce bycatch in prawn trawls: a review and framework for development. *Reviews in Fish Biology and Fisheries* **10**, 27–60.
- Broadhurst, M.K. and Hazin, F.H.V. (2001) Influences of type and orientation of bait on catches of swordfish (*Xiphias gladius*) and other species in an artisanal sub-surface longline fishery off northeastern Brazil. *Fisheries Research* **53**, 169–179.
- Broadhurst, M.K., McShane, P.E. and Larsen, R.B. (2000) Effects of twine diameter and mesh size in the body of prawn trawls used in Gulf St. Vincent, Australia. *Fishery Bulletin* **98**, 463–473.
- Brylinsky, M., Gibson, J. and Gordon, D.C. (1994) Impacts of flounder trawls on the intertidal habitat and community of the Minas Basin, Bay of Fundy. *Canadian Journal of Fisheries and Aquatic Sciences* **51**, 650–661.
- Carr, H.A. and Milliken, H. (1998) Conservation engineering: options to minimize fishing's impacts to the sea floor. In: *Effects of Fishing Gear on the Sea Floor of New England* (eds E.M. Dorsey and J. Pederson). Conservation Law Foundation, Boston, Massachusetts, pp. 100–103.
- Collie, J. (1998) Studies in New England of fishing gear impacts on the sea floor. In: *Effects of Fishing Gear on the Sea Floor of New England* (eds E.M. Dorsey and J. Pederson). Conservation Law Foundation, Boston, Massachusetts, pp. 53–62.
- Collie, J.S., Escanero, G.A. and Valentine, P.C. (1997) Effects of bottom fishing on the benthic megafauna of Georges Bank. *Marine Ecology Progress Series* **155**, 159–172.
- Currie, D.R. and Parry, G.D. (1996) Effects of scallop dredging on a soft sediment community: a large-scale experimental study. *Marine Ecology Progress Series* **134**, 131–150.
- Dannevig, H.C. (1904) *Preliminary report upon the prawning industry in Port Jackson*. W A Gullick, NSW Government Printer, 17pp.
- Dayton, P.K., Thrush, S.F., Agardy, M.T. and Hofman, R.J. (1995) Environmental effects of marine fishing. *Aquatic Conservation: Marine and Freshwater Ecology* **5**, 205–232.
- DeAlteris, J., Skrobe, L. and Lipsky, C. (1999) The significance of seabed disturbance by mobile fishing gear relative to natural processes: a case study in Narragansett Bay, Rhode Island. *American Fisheries Society Symposium* **22**, 224–237.
- Dorsey, E.M. and Pederson, J., eds (1998) *Effects of fishing gear on the sea floor of New England*. Conservation Law Foundation, Boston, MA, 160pp.
- Dyson, J. (1977) *Business in Great Waters: the story of British Fishermen*. Angus & Robertson (UK) Ltd., UK, pp. 37–39.
- Eleftheriou, A. and Robertson, M.R. (1992) The effects of experimental scallop dredging on the fauna and physical environment of a shallow sandy community. *Netherlands Journal of Sea Research* **30**, 289–299.
- Freese, L., Auster, P.J., Heifetz, J. and Wing, B.L. (1999) Effects of trawling on seafloor habitat and associated invertebrate taxa in the Gulf of Alaska. *Marine Ecology Progress Series* **182**, 119–126.
- Friedlander, A.M., Boehlert, G.W., Field, M.E., Mason, J.E., Gardner, J.V. and Dartnell, P. (1999) Sidescan-sonar mapping of benthic trawl marks on the shelf and slope off Eureka, California. *Fishery Bulletin* **97**, 786–801.

- Gilkinson, K., Paulin, M., Hurley, S. and Schwinghamer, P. (1998) Impacts of trawl door scouring on infaunal bivalves: results of a physical door model–dense sand interaction. *Journal of Experimental Marine Biology and Ecology* **224**, 291–312.
- Gordon, D.C., Schwinghamer, P., Rowell, T.W. *et al.* (1998) Studies in eastern Canada on the impact of mobile fishing gear on benthic habitat and communities. In: *Effects of Fishing Gear on the Sea Floor of New England* (eds E.M. Dorsey and J. Pederson). Conservation Law Foundation, Boston, MA, pp. 63–67.
- Gray, C.A., Larsen, R.B. and Kennelly, S.J. (2000) Use of transparent netting to improve size selectivity and reduce by-catch in fish seine nets. *Fisheries Research* **45**, 155–166.
- Hall, M.A. (1994) By-catches in purse-seine fisheries. In: *By-catches in Fisheries and their Impact on the Ecosystem*, Vol. 2 (1) (eds T. J. Pitcher and R. Chuenpagdee) ISSN 1198–6727. Fisheries Centre Research Reports. University of British Columbia, Canada, pp. 53–58 [see appendix for availability of unpublished reports (1)].
- Hall, M.A. (1998) An ecological view of the tuna–dolphin problem: impacts and trade-offs. *Reviews in Fish Biology and Fisheries* **8**, 1–34.
- Hall-Spencer, J.M., Froggia, C., Atkinson, R.J.A. and Moore, P.G. (1999) The impact of Rapido trawling for scallops, *Pecten jacobaeus* (L.), on the benthos of the Gulf of Venice. *ICES Journal of Marine Science* **56**, 111–124.
- Hansson, M., Lindegarth, M., Valentinsson, D. and Ulmestrand, M. (2000) Effects of shrimp-trawling on abundance of benthic macro-fauna in Gullmarsfjorden, Sweden. *Marine Ecology Progress Series* **198**, 191–201.
- Hay, D.E., Cooke, K.D. and Gissing, C.V. (1986) Experimental studies of Pacific herring gillnets. *Fisheries Research* **4**, 191–211.
- Hill, A.S., Veale, L.O., Pennington, S.G., Whyte, S.G., Braund, A.R. and Hartnoll, R.G. (1999) Changes in Irish sea benthos: possible effects of 40 years of dredging. *Estuarine, Coastal Shelf and Science* **48**, 739–750.
- Hovgård, H. (1996) Effect of twine diameter on fishing power of experimental gill nets used in Greenland waters. *Canadian Journal of Fisheries and Aquatic Sciences* **53**, 1014–1017.
- Isaksen, B., Valdemarsen, J.W., Larsen, R.B. and Karlsen, L. (1992) Reduction of fish by-catch in shrimp trawl using a rigid separator grid in the aft belly. *Fisheries Research* **13**, 335–352.
- Jennings, S. and Kaiser, M.J. (1998) The effects of fishing on marine ecosystems. *Advances in Marine Biology* **34**, 201–352.
- Jennings, S. and Polunin, N.V.C. (1997) Impacts of predator depletion by fishing on the biomass and diversity of non-target reef fish communities. *Coral Reefs* **16**, 71–82.
- Jennings, S., Greenstreet, S.P.R. and Reynolds, J.D. (1999) Structural change in an exploited fish community: a consequence of differential fishing effects on species with contrasting life histories. *Journal of Animal Ecology* **68**, 617–627.
- Kaiser, M.J. (1996) Starfish damage as an indicator of trawling intensity. *Marine Ecology Progress Series* **134**, 303–307.
- Kaiser, M.J. (1998) Significance of bottom-fishing disturbance. *Conservation Biology* **12**, 1230–1235.
- Kaiser, M.J. and Ramsay, K. (1997) Opportunistic feeding by dabs within areas of trawl disturbance: possible implications for increased survival. *Marine Ecology Progress Series* **152**, 307–310.
- Kaiser, M.J. and Spencer, B.E. (1994) Fish scavenging behaviour in recently trawled areas. *Marine Ecology Progress Series* **112**, 41–49.
- Kaiser, M.J. and Spencer, B.E. (1996) The effects of beam-trawl disturbance on infaunal communities in different habitats. *Journal of Animal Ecology* **65**, 348–358.
- Kaiser, M.J., Cheney, K., Spence, F.E., Edwards, D.B. and Readford, K. (1999) Fishing effects in northeast Atlantic shelf seas: patterns in fishing effort, diversity and community structure. Part VII. The effects of trawling disturbance on the fauna associated with the tubeheads of serpulid worms. *Fisheries Research* **40**, 195–205.
- Kaiser, M.J., Edwards, D.B., Armstrong, P.J. *et al.* (1998) Changes in megafaunal benthic communities in different habitats after trawling disturbance. *ICES Journal of Marine Science* **55**, 353–361.
- Kaiser, M.J., Hill, A.S., Ramsay, K. *et al.* (1996) Benthic disturbance by fishing gear in the Irish sea: a comparison of beam trawling and scallop dredging. *Aquatic Conservation: Marine and Freshwater Ecology* **6**, 269–285.
- Kennelly, S.J. (1995) The issue of by-catch in Australia's demersal trawl fisheries. *Reviews in Fish Biology and Fisheries* **5**, 213–234.
- Kennelly, S.J. (1997) A framework for solving by-catch problems: examples from New South Wales, Australia, the eastern Pacific and the northwest Atlantic. In: *Developing and Sustaining World Fisheries Resources: the State of Science and Management* (eds D.A. Hancock, D.C. Smith, A. Grant and J.P. Beumer). 2nd World Fisheries Congress proceedings. ISBN 0–643–05985–7. CSIRO Press, Australia, pp. 544–550.
- Kennelly, S.J. (1999) The development and introduction of by-catch reducing technologies in three Australian prawn-trawl fisheries. *Marine Technology Society Journal* **33**, 73–81.
- Kennelly, S.J. and Broadhurst, M.K. (1996) Fishermen and scientists solving by-catch problems: examples from Australia and possibilities for New England. In: *Solving By-catch: Considerations for Today and Tomorrow*. Alaska Sea Grant College Program Report no. 96–03. University of Alaska Fairbanks, pp. 121–128.
- Kennelly, S.J. and Gray, C.A. (2000) Reducing the mortality of discarded undersize sand whiting *Sillago ciliata* in an estuarine seine fishery. *Marine and Freshwater Research* **51**, 749–753.

- Kennelly, S.J., Kearney, R.E., Liggins, G.W. and Broadhurst, M.K. (1993) The effect of shrimp trawling by-catch on other commercial and recreational fisheries – an Australian perspective. In: *International Conference on Shrimp By-catch, May 24–27, 1992, Lake Buena Vista, Florida* (ed. R.P. Jones). Southeastern Fisheries Association, Tallahassee, FL, pp. 97–114.
- Kennelly, S.J., Liggins, G.W. and Broadhurst, M.K. (1998) Retained and discarded by-catch from oceanic prawn trawling in New South Wales, Australia. *Fisheries Research* **36**, 217–236.
- Liggins, G.W. and Kennelly, S.J. (1996) By-catch from prawn trawling in the Clarence River estuary, New South Wales, Australia. *Fisheries Research* **25**, 347–367.
- Lindeboom, H.J. and de Groot S.J., eds (1998) *The Effects of Different Types of Fisheries on the North Sea and Irish Sea Benthic Ecosystems*. Netherlands Institute for Sea Research (NIOZ). Netherlands Institute for Fisheries Research (RIVO-DLO), the Netherlands, 404pp.
- Lindgarth, M., Valentinsson, D., Hansson, M. and Ulmestrand, M. (2000a) Disturbances by trawling changes temporal and spatial structure of benthic soft-sediment assemblages in Gullmars-fjorden, Sweden. *ICES Journal of Marine Science* **57**, 1369–1376.
- Lindgarth, M., Valentinsson, D., Hansson, M. and Ulmestrand, M. (2000b) Interpreting large-scale experiments on effects of trawling on benthic fauna: an empirical test of the potential effects of spatial confounding in experiments without replicated control and trawled areas. *Journal of Experimental Marine Biology and Ecology* **245**, 155–169.
- Lindeman, K.C. and Snyder, D.B. (1999) Nearshore hard-bottom fishes of southeast Florida and effects of habitat burial caused by dredging. *Fishery Bulletin* **97**, 508–525.
- Løkkeborg, S. (1998) Seabird by-catch and bait loss in longlining using different setting methods. *ICES Journal of Marine Science* **55**, 145–149.
- Løkkeborg, S. and Bjordal, Å. (1992) Species and size selectivity in longline fishing: a review. *Fisheries Research* **13**, 311–322.
- Medina, H. (1994) Reducing by-catch through gear modifications: the experience of the tuna–dolphin fishery. In: *By-catches in Fisheries and Their Impact on the Ecosystem* Vol. 2 (1) (eds T.J. Pitcher and R. Chuenpagdee) ISSN 1198–6727. Fisheries Centre Research Reports, University of British Columbia, Canada, p. 60 [see appendix for availability of unpublished reports (1)].
- Morton, B. (1996) The subsidiary impacts of dredging (and trawling) on a subtidal benthic molluscan community in the southern waters of Hong Kong. *Marine Pollution Bulletin* **32**, 701–710.
- NOAA (2001) Brief history of groundfishing. NOAA NMFS. Available at: <http://www.noaa.gov/nmfs/groundfish/grndfshl.html>.
- Nun, M. (1989) *The Sea of Galilee and Its Fishermen in the New Testament*. Ein Gev, Kibbutz Ein Gev.
- Nun, M. (1993) Cast your net upon the waters: fish and fishermen in Jesus' time. *Biblical Archaeology Review* **19**, 6, 70.
- Pilskaln, C.H., Churchill, J.H. and Mayer, L.M. (1998) Resuspension of sediment by bottom trawling in the Gulf of Maine and potential geochemical consequences. *Conservation Biology* **12**, 1223–1229.
- Pitcher, T.J. (2001) Rebuilding ecosystems as a new goal for fisheries management: reconstructing the past to salvage the future. *Ecological Applications* **11**, 601–617.
- Poiner, I., Glaister, J., Pitcher, R. et al. (1998) *Final Report on Effects of Trawling in the Far Northern Section of the Great Barrier Reef: 1991–96*. CSIRO Division of Marine Research, Cleveland.
- Poulsen, S., Nielsen, J.R., Holst, R. and Stæhr, K. (2000) An Atlantic herring (*Clupea harengus*) size selection model for experimental gill nets used in the Sound (ICES Subdivision 23). *Canadian Journal of Fisheries and Aquatic Sciences* **57**, 1551–1561.
- Pranovi, F., Giovanardi, O. and Franceschini, G. (1998) Recolonization dynamics in areas disturbed by bottom fishing gears. *Hydrobiologia* **375/376**, 125–135.
- Prena, J., Schwinghamer, P., Rowell, T.W. et al. (1999) Experimental otter trawling on a sandy bottom ecosystem of the Grand Banks of Newfoundland: analysis of trawl by-catch and effects on epifauna. *Marine Ecology Progress Series* **181**, 107–124.
- Ramsay, K., Kaiser, M.J. and Hughes, R.N. (1996) Changes in hermit crab feeding patterns in response to trawling disturbance. *Marine Ecology Progress Series* **144**, 63–72.
- Ramsay, K., Kaiser, M.J. and Hughes, R.N. (1998) Responses of benthic scavengers to fishing disturbance by towed gears in different habitats. *Journal of Experimental Marine Biology and Ecology* **224**, 73–89.
- Rogers, S.I., Kaiser, M.J. and Jennings, S. (1998) Ecosystem effects of demersal fishing: a European perspective. In: *Effects of Fishing Gear on the Sea Floor of New England* (eds E.M. Dorsey and J. Pederson). Conservation Law Foundation, Boston, MA, pp. 68–78.
- Sainsbury, K.J. (1991) Application of an experimental approach to management of a tropical multispecies fishery with highly uncertain dynamics. *ICES Marine Science Symposia* **193**, 301–320.
- Sainsbury, K.J., Campbell, R.A., Lindholm, R. and Whitelaw, A.W. (1997) Experimental management of an Australian multispecies fishery: examining the possibility of trawl-induced habitat modification. In: *Global Trends: Fisheries Management* (eds E.L. Pikitch, D.D. Huppert and M.P. Sissenwine). American Fisheries Society Symposium 20, Bethesda, MD, pp. 107–112.
- Schwinghamer, P., Gordon, D.C., Rowell, T.W. et al. (1998) Effects of experimental otter trawling on surficial sediment properties of a sandy-bottom ecosystem on the Grand Banks of Newfoundland. *Conservation Biology* **12**, 1215–1222.

- Seidel, W.R. (1969) Design, construction and field testing of the BCF electric shrimp trawl system. *Fishery Industrial Research* **4**, 213–231.
- Simboura, N., Zenetos, A., Pancucci-Papadopoulou, M., Thessalou-Legaki, M. and Papaspyrou, S. (1998) A baseline study on benthic species distribution in two neighbouring gulfs, with and without access to bottom trawling. *Marine Ecology* **19**, 293–309.
- Stewart, J. and Ferrell, D.J. (2002) Mesh selectivity in the New South Wales demersal trap fishery. *Fisheries Research* in press.
- Tegner, M.J. and Dayton, P.K. (1999) Ecosystem effects of fishing. *Trends in Ecology and Evolution* **14**, 261–262.
- Thrush, S.F., Hewitt, J.E., Cummings, V.J. and Dayton, P.K. (1995) The impact of habitat disturbance by scallop dredging on marine benthic communities: what can be predicted from the results of experiments? *Marine Ecology Progress Series* **129**, 141–150.
- Thrush, S.F., Hewitt, J.E., Cummings, V.J. *et al.* (1998) Disturbance of the marine benthic habitat by commercial fishing: impacts at the scale of the fishery. *Ecological Applications* **8**, 866–879.
- Tuck, I.D., Hall, S.J., Robertson, M.R., Armstrong, E. and Basford, D.J. (1998) Effects of physical trawling disturbance in a previously unfished sheltered Scottish sea loch. *Marine Ecology Progress Series* **162**, 227–242.
- Watling, L. and Norse, E.A. (1998) Disturbance of the sea bed by mobile fishing gear: a comparison to forest clearcutting. *Conservation Biology* **12**, 1180–1197.
- Watson, J.W. (1976) Electrical shrimp trawl catch efficiency for *Penaeus duorarum* and *Penaeus aztecus*. *Transactions of the American Fisheries Society* **105**, 135–148.
- Witbaard, R. and Klein, R. (1994) Long-term trends on the effects of southern North Sea beamtrawl fishery on the bivalve mollusc *Artica islandica* L. (Mollusca, bivalvia). *ICES Journal of Marine Science* **51**, 99–105.
- Wuellner, W. (1967) *The Meaning of 'Fishers of Men'*. New Testament Library. Westminster Press, Philadelphia, 256pp.
- Yellen, J.E., Brooks, A.S., Cornelissen, E., Mehlman, M.J. and Stewart, K. (1995) A middle stone age worked bone industry from Katanda, Upper Semliki Valley, Zaire. *Science* **268**, 553–555.